

PMM/KS/15/7005



Faculty of Engineering & Technology

Fourth Semester B.E. (Mechanical Engg.) (C.B.S.)

Examination

MECHANICS OF MATERIALS

Time—Three Hours]

[Maximum Marks—80

INSTRUCTIONS TO CANDIDATES

- (1) All questions carry marks as indicated.
- (2) Solve **SIX** questions as follows :
 - Q. No. 1 OR Q. No. 2
 - Q. No. 3 OR Q. No. 4
 - Q. No. 5 OR Q. No. 6
 - Q. No. 7 OR Q. No. 8
 - Q. No. 9 OR Q. No. 10
 - Q. No. 11 OR Q. No. 12.
- (3) Due credit will be given to neatness and adequate dimensions.
- (4) Illustrate your answers wherever necessary with the help of neat sketches.
- (5) Use of Drawing instruments is permitted.
- (6) Use of Non-programmable calculator is permitted.

MMW—40562

1

(Contd.)

- (7) Use of Design Data Book is permitted.
 (8) Assume suitable data wherever necessary.

1. (a) Explain Poisson's Ratio. 3
 (b) Define factor of safety. State the factors on which selection of factor of safety depends. 3
 (c) A composite bar made up of steel and aluminium is held between two supports. The bar is stress free at 40 °C. What will be the stresses in the two bars when the temperature is 20 °C if :
 (i) Supports do not yield
 (ii) The supports come nearer to each other by 0.1 mm ?

Given : $E_{st} = 210 \text{ GPa}$; $E_{Al} = 74 \text{ GPa}$

$\alpha_{st} = 11.7 \times 10^{-6}/^{\circ}\text{C}$; $\alpha_{Al} = 23.4 \times 10^{-6}/^{\circ}\text{C}$

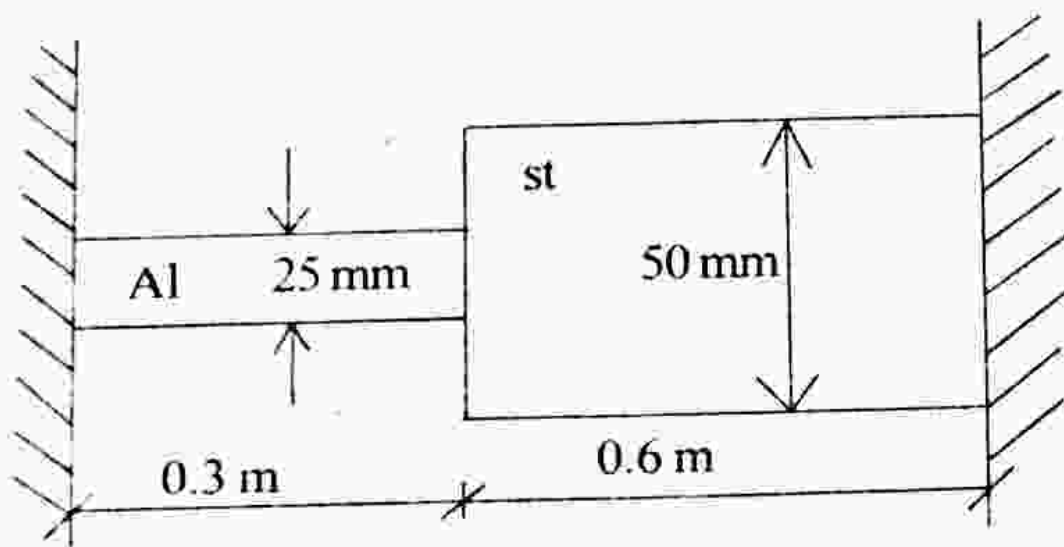

Fig. 1 (c)

OR

2. (a) A rectangular block $200 \text{ mm} \times 80 \text{ mm} \times 60 \text{ mm}$ is subjected to axial loads as follows :

(i) 480 kN (T) in the direction of its length (i.e. 200 mm)

(ii) 800 kN (C) on $200 \text{ mm} \times 80 \text{ mm}$ face

(iii) 900 kN (T) on $200 \text{ mm} \times 60 \text{ mm}$ face.

Find change in the volume of the block. Take $\mu = 0.25$ and $E = 2 \times 10^5 \text{ N/mm}^2$. 6

(b) A rigid beam AB 240 cm long is hinged at A and supported by two steel wires CD and EF as shown in Fig. 2 (b) ; wire CD is 6 m long and 12 mm in diameter whereas wire EF is 3 m long and 8 mm in diameter. Find stresses in each wire.

Take $E = 2 \times 10^5 \text{ MPa}$. 7

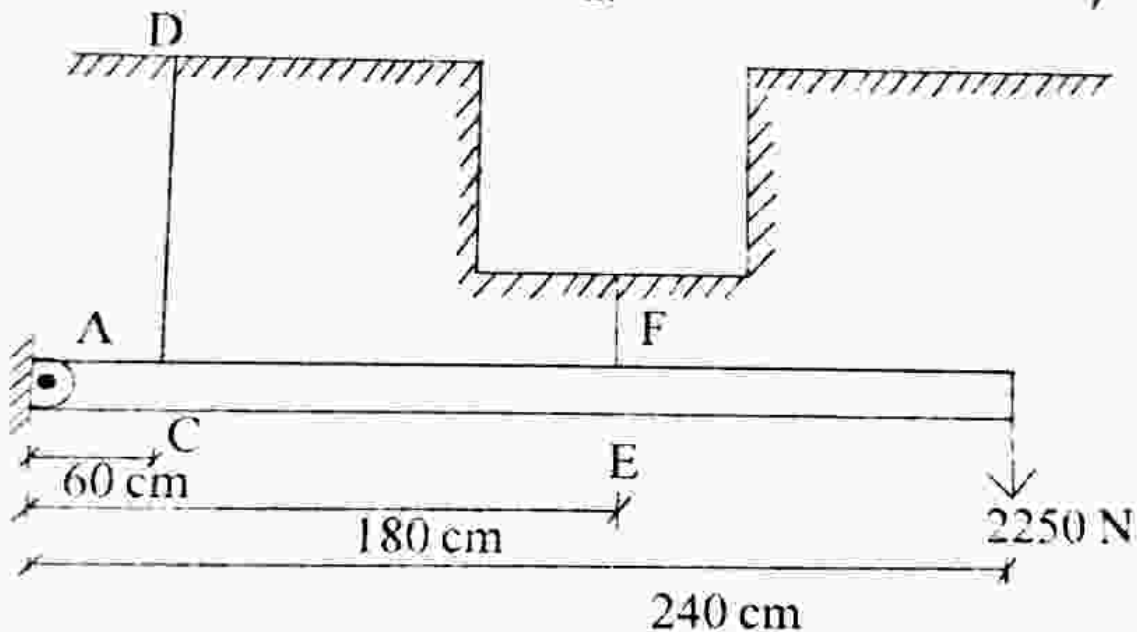

Fig. 2 (b)

3. Draw the shear force and bending moment diagram for the beam as shown in Figure 3. Also calculate the maximum bending moment.

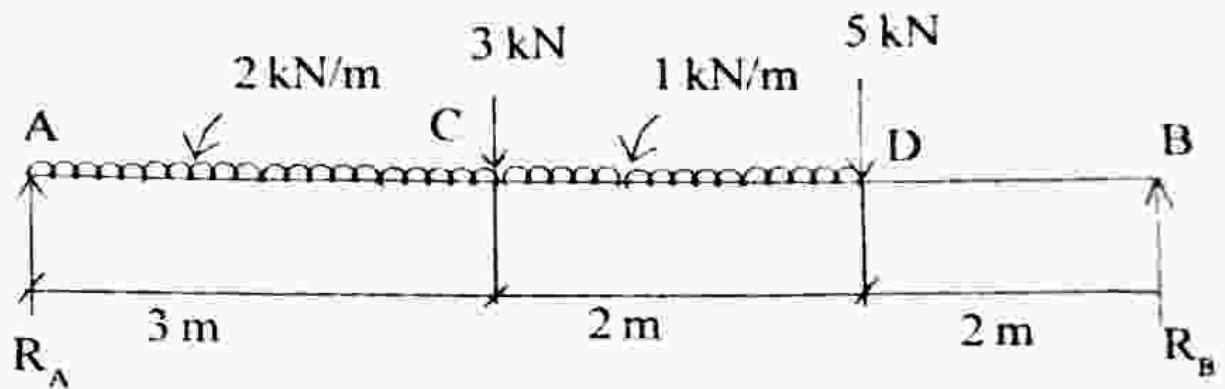

Fig. 3

14

OR

4. (a) A horizontal beam of uniform cross-section and 10 m long is simply supported at 2 m from each end ; so that the distance between two supports is 6 m and each overhang is 2 m. This beam carries UDL of 4.6 kN/m over its entire length. The cross-section is shown in Fig. 4 (a). Find the maximum value of tensile and compressive stress developed in the beam.

9

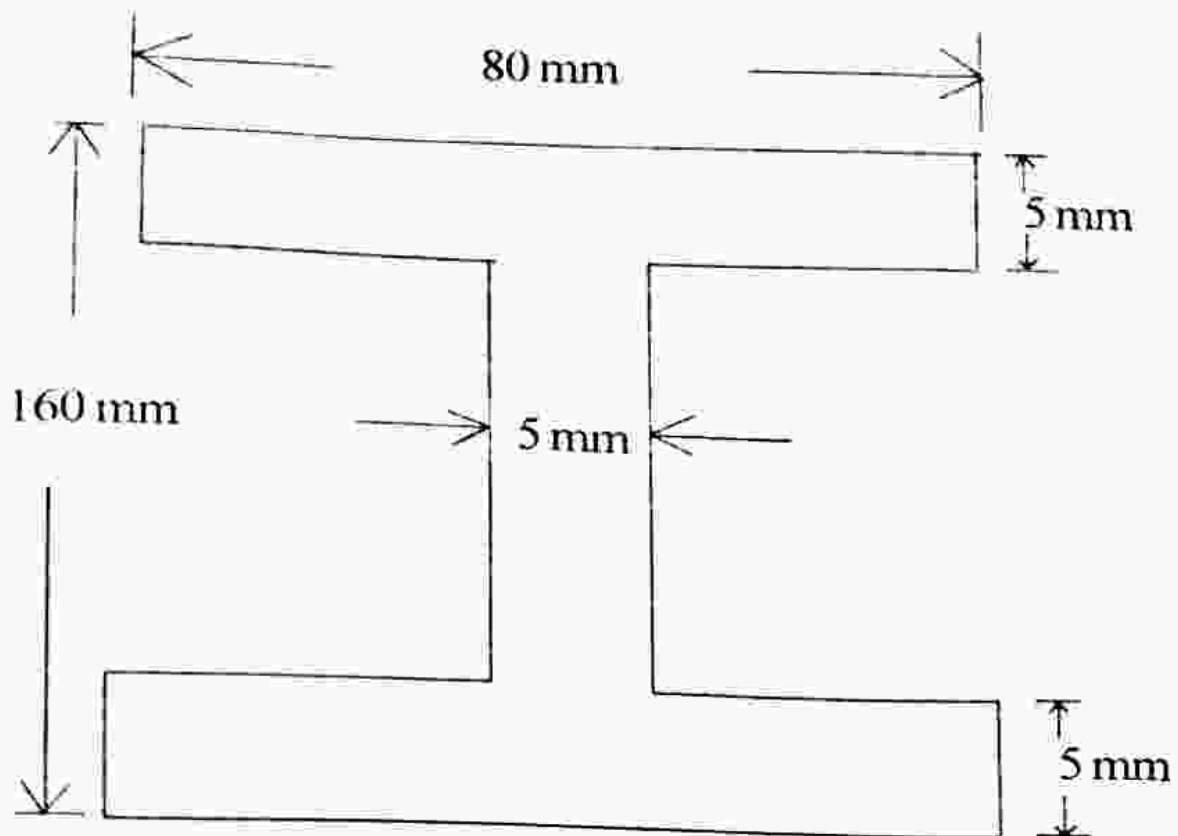

Fig. 4 (a)

- (b) Prove that the maximum shear stresses over a circular section is $\frac{4}{3}$ times the average shear stress :

$$\tau_{\max} = \frac{4}{3} \tau_{\text{average}} \quad 5$$

5. A beam PQRS shown in Fig. 5, $PQ = QR = 1$ m, $RS = 2$ m is supported at P and S. It carries concentrated load of 20 kN at Q and VDL of 10 kN/m on span RS. Determine deflection of the beam at Q and R. Also find slope at the centre of the beam. Take $E = 200$ GPa ;

$$I = 20 \times 10^6 \text{ m}^4.$$

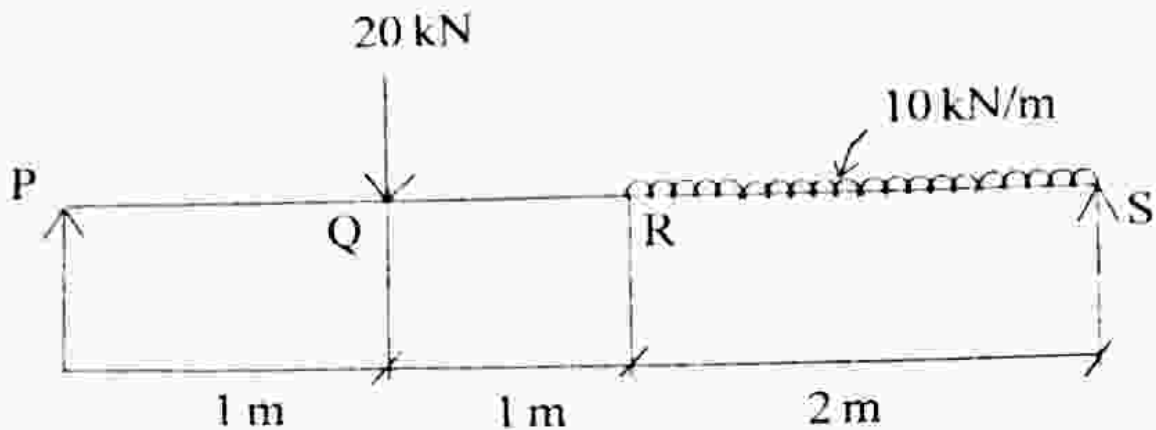

Fig. 5
OR

13

6. (a) A plane element is subjected to stresses as shown in Fig. 6 (a) :
- Determine analytically the principal stresses and their directions
 - The maximum shearing stresses and the directions of the plane on which they occur
 - Check the answer by using Mohr's circle method.

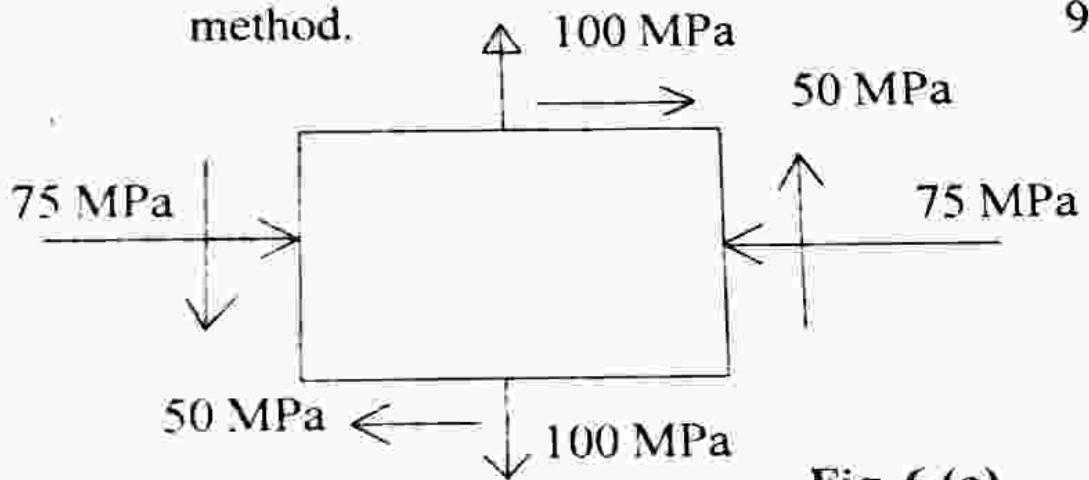

Fig. 6 (a)

- (b) An element is subjected to uniaxial state of stress in x-direction of intensity σ_x . Derive the expression for normal stress σ_θ and shear stress τ_θ acting on a plane inclined at angle θ to x-axis. 4

7. (a) Prove the relation :

$$\frac{T}{J} = \frac{\sigma_s}{R} = \frac{C\theta}{L}$$

where,

T = Torque transmitted

J = Polar moment of inertia

σ_s = Maximum shear stress

R = Radius of shaft

C = Modulus of rigidity

θ = Angle of twist

L = Length of shaft. 5

- (b) A hollow shaft of diameter ratio $3/8$ is required to transmit 600 kW at 110 rpm, the maximum torque being 20% greater than mean torque. Shear stress in the material should not exceed 63 MPa and the twist in the length of 3 m is not to exceed 1.4° . Calculate the dimensions of the shaft satisfying the above conditions.

Given $C = 84$ GPa. 8

OR

7

(Contd.)

8. (a) For a hollow cast iron column with outside diameter 200 mm and thickness 25 mm, length 4.5 m with both the ends fixed, calculate the safe load by Rankine formula using factor of safety 4. Also calculate slenderness ratio and ratio of Euler's to Rankine load.

$$\text{Given } \sigma_c = 550 \text{ N/mm}^2 ; \alpha = \frac{1}{1600}$$

$$E = 9.4 \times 10^4 \text{ N/mm}^2. \quad 9$$

- (b) Define the following terms :
- (i) Slenderness ratio
 - (ii) Crippling load. 4
9. (a) Explain in brief various phases of creep phenomenon. 5
- (b) A 10 mm diameter mild steel bar of length 1.5 m is stretched by a weight of 120 N dropping freely through 20 mm before commencing to stretch the bar. Find the maximum instantaneous stress and elongation produced in the bar. 8

OR

10. (a) What are the various modes of fracture ? Explain the effect of thickness and flow size on fracture. 5

(b) A vertical round steel bar 2100 mm long is securely held at its upper end. A weight falls through a height of 30 mm on the stop provided at the bottom and the maximum stress produced in the bar was 163 MPa. Determine the stress when the load is applied :

(i) Gradually

(ii) Suddenly

(iii) Through a height of 50 mm

Given $E = 2 \times 10^5 \text{ N/mm}^2$.

8

11. (a) Explain different theories of failure in detail.

4

(b) A shaft made up of 5 AE 1030 is subjected to the following loading conditions :

(i) Axial load 10 kN

(ii) Torque 250 Nm

(iii) Bending moment 300 Nm.

Determine factor of safety using maximum principal stress theory and maximum shear stress theory for a shaft of diameter 50 mm.

10

OR

12. A shaft of diameter 50 mm made up of SAE 1020 is subjected to the following loading conditions :

- (i) Axial load varying from 15 kN (T) to 5 kN (C)
- (ii) Bending moment varying from 450 Nm (CW) to 150 Nm (CCW)
- (iii) Torque varying from 350 Nm (CW) to 100 Nm (CCW).

The expected reliability is 95% and the system operates at room temperature with no stress risers. Determine the factor of safety for a ground finish. 14

www.solveout.in