

B.E. Fifth Semester (Computer Science Engineering) (C.B.S.)  
**Design & Analysis of Algorithms**

P. Pages : 3

Time : Three Hours



**NKT/KS/17/7353**

Max. Marks : 80

- Notes :
1. All questions carry marks as indicated.
  2. Solve Question 1 OR Questions No. 2.
  3. Solve Question 3 OR Questions No. 4.
  4. Solve Question 5 OR Questions No. 6.
  5. Solve Question 7 OR Questions No. 8.
  6. Solve Question 9 OR Questions No. 10.
  7. Solve Question 11 OR Questions No. 12.
  8. Assume suitable data whenever necessary.
  9. Illustrate your answers whenever necessary with the help of neat sketches.

1. a) Differentiate between following. 6  
 i) Homo  
 ii) Change of variable method and characteristic root method.

- b) Solve the following non-homogenous recurrence relation. 7

$$T(n) = \begin{cases} 1 & \text{if } n = 0 \\ 3T(n-1) + 2^n + 5 & \text{otherwise} \end{cases}$$

**OR**

2. a) Solve the following using master method. 8

- |                              |                                    |
|------------------------------|------------------------------------|
| 1) $T(n) = 2T(n/4) + n$      | 2) $T(n) = 3T(8n/4) + n^2$         |
| 3) $T(n) = 6T(n/8) + \log n$ | 4) $T(n) = 7T(n/5) + \sqrt{n} + 2$ |

- b) Explain algorithm design strategy in detail? 5

3. a) Explain all the methods of Amortized Analysis for 4-bit binary increment operation. 7

- b) What is bitonic sorting network explain half cleaner and clean the following sequence using half cleaner? 7

0 1 0 0    1 1 0 0

**OR**

4. Perform the following operation on Fibonacci heap.

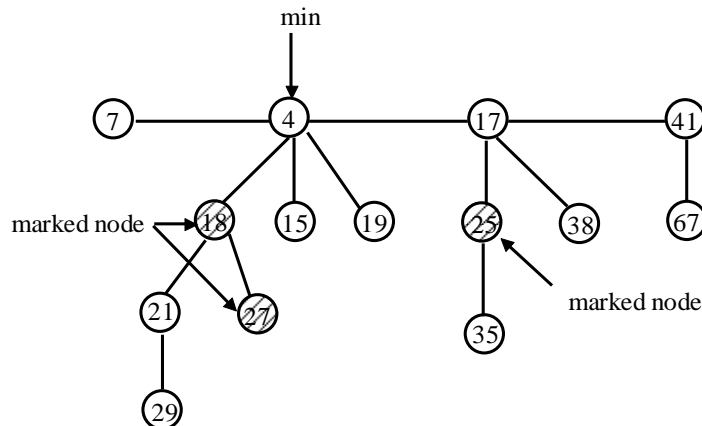

- 1) Delete the min node. 7
  - 2) Calculate potential function of given Fibonacci heap. 2
  - 3) Decrement 35 by 5. 3
  - 4) Insert 21 in the given Fibonacci heap. 2
5. a) Explain Analysis of binary search for following elements and calculate Avg. no. of successful and Avg no. of unsuccessful comparisons  
-10, 25, 15, 16, 18, -9, 4, 2. 7
- b) Explain greedy strategy and write an algorithm for coin selection problem? 6

**OR**

6. a) Write an algorithm for partial knapsack and solve following. 7  
 $n = 5$   $M=15$   
 $p = (10, 15, 20, 16, 9)$   
 $w = (2, 8, 6, 5, 3)$   
 where  $M = \text{Capacity}$ .
- b) Calculate minimum and maximum element from following array using min-max algorithm. 6  
 20, 19, 17, -15, 16, 20, 19.
7. a) Differentiate between: 4  
 1) Dynamic programming & Greedy strategy.  
 2) Dynamic programming & Divide and conquer.
- b) Write an algorithm for Floyd Warshall and calculate distance and path matrix of following. 10

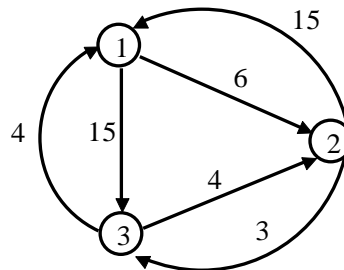

**OR**

8. a) Calculate the minimum no. of scalar multiplication for following set of matrix using matrix chain multiplication? 7  
 $A_1 = 10 \times 20$   
 $A_2 = 20 \times 13$   
 $A_3 = 13 \times 15$   
 $A_4 = 15 \times 12$   
 Also write correct parenthesization?

b) What is TSP? Calculate the TSP tour for following matrix. 7

$$\begin{bmatrix} 0 & 9 & 8 & 7 \\ 10 & 0 & 6 & 5 \\ 12 & 13 & 0 & 8 \\ 2 & 3 & 5 & 0 \end{bmatrix}$$

9. a) What is Hamaltonian cycle? Write an algorithm to generate Hamaltonian cycle? 7

b) What is Articulation Point? Write a steps to find Articulation point? 6

**OR**

10. a) Explain Implicit and Explicit constraints write a formula to calculate implicit and Explicit constraints? 7

b) Solve the following using sum of sub-set method. 6

$$W = 15 \ 5 \ 10 \ 20$$

$$M = 30$$

11. Write an algorithm for following graph reduction method. 13

i) Clique.

ii) Graph partition into trangee.

iii) Independent set problem.

**OR**

12. a) Write an algorithm for Nondeterministic searching & sorting? 6

b) Explain following terms.

1) NP-Hard. 1

2) Polynomial Reduction. 3

3) Decision & optimisation problem. 3

\*\*\*\*\*

